

**NEW!**

## Landfill Gas Packages

Gardner Denver, with its premium Lamson, Hoffman and Turbotron products, has the longest history of providing durable and cost effective exhausters and blowers to the Landfill Gas industry. Gardner Denver brands were instrumental in converting landfill gas owners to cast iron multistage centrifugal blowers as the gas-moving technology of choice for their landfills. Today, in addition to flare applications, more blowers are being used in Gas to Energy plants (LFGTE), as well as in leachate evaporation systems.

In an effort to provide the most cost effective and durable blowers/exhausters for landfill gas, Gardner Denver has designed specific packages pre-engineered to better resist corrosion and gas leakage. The resulting landfill gas packages will provide years of dependable, maintenance-free service.

### **MOST RELIABLE**

- Fewer moving parts; less downtime
- Heavy-duty cast iron construction
- Baked phenolic coated heads and sections
- Dynamically balanced rotor assemblies available

### **ESSENTIALLY MAINTENANCE-FREE**

- Sealed bearings (grease-free up to 1260 frame)
- No lubrication changes required
- Quick access drain line and valve
- Non-contacting, multi-groove labyrinth seals
- Orange peel coupling guard with non-sparking design

### **MOST EFFICIENT MACHINES ON THE MARKET**

- Baffle rings standard on 550 units and above
- More model options so you can select one best-suited to maximize your plant's efficiency
- Standard with EPACT or premium efficient motors (VFD ready with space heaters)



## Landfill Gas Package

**HOFFMAN  
LAMSON**



**FAST DELIVERY**

Bare Blowers | Packages  
2-4 weeks | 6-8 weeks

## Landfill Gas Packages

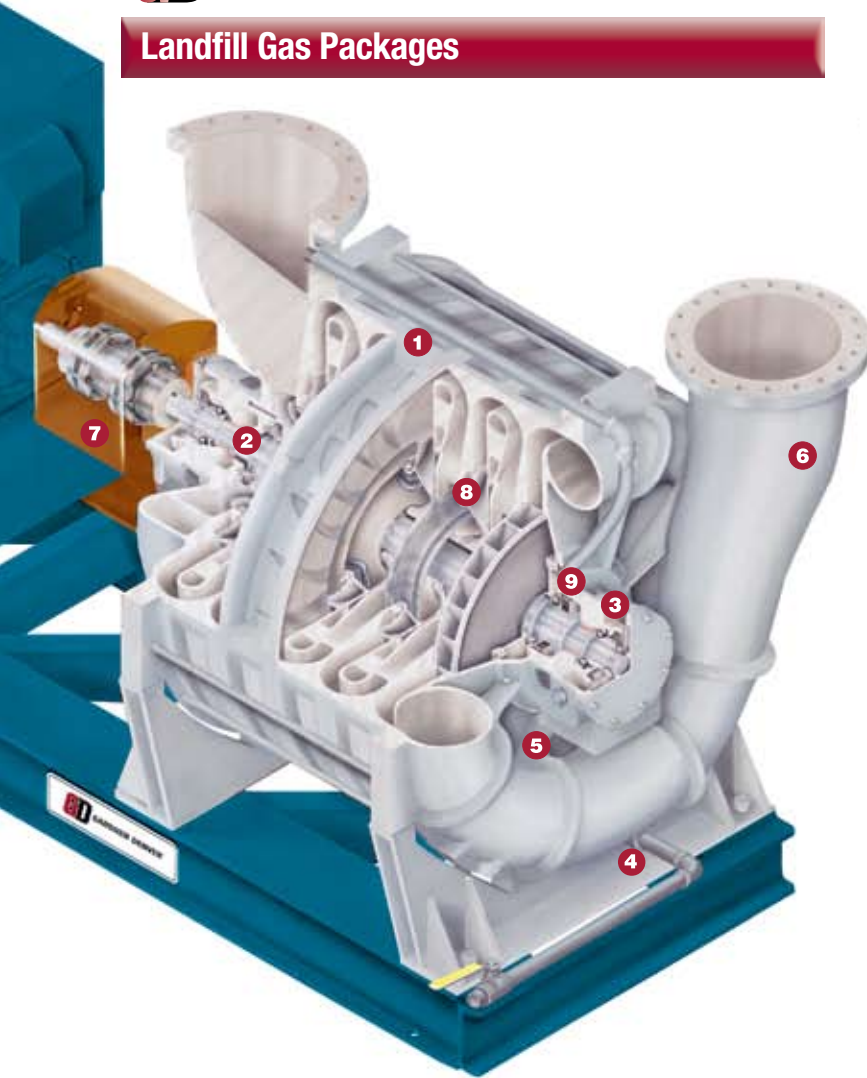

### Gardner Denver Performance Specifications – Typical Landfill Offerings

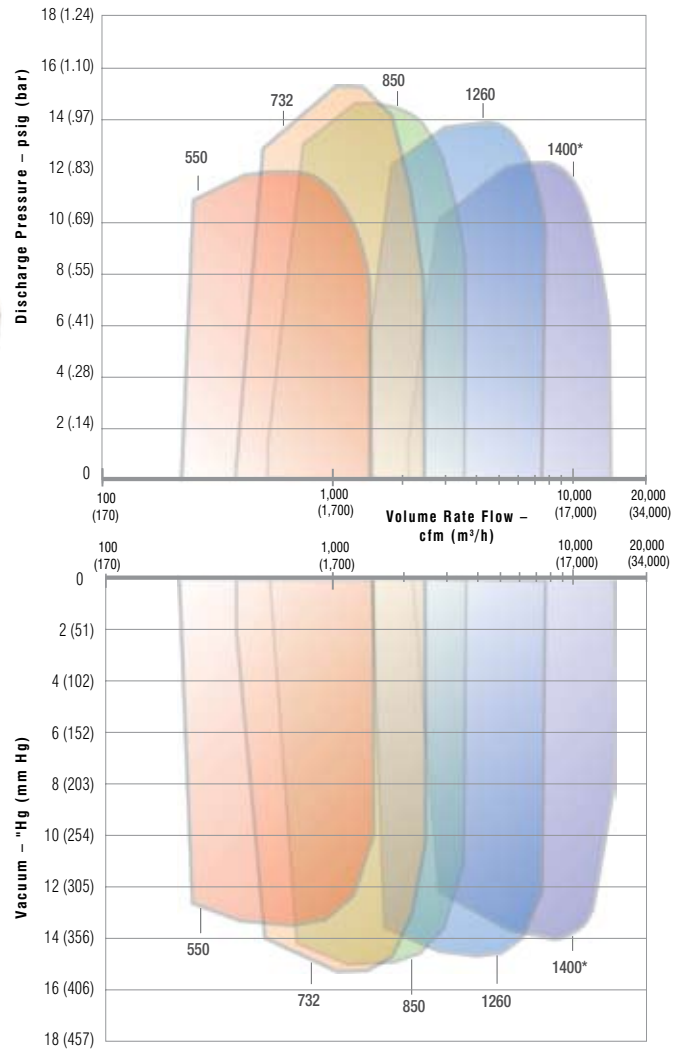

**Superior Quality and Design - By the Numbers**



	Key Feature	Benefit
	1. Coated Heads and Sections	Corrosion Resistant
NEW!	2. Upgraded Multi-Lip Labyrinth Seals	Minimum Gas Leakage (carbon ring optional)
NEW!	3. Sealed for Life Bearings (up to 1260 frame)	Zero Maintenance; Sealed From Gas and Moisture
NEW!	4. Drain Line with Valve	Quickly and Easily Removes Condensate
NEW!	5. Provisions for Bearing Monitoring	Field or Remote Monitoring (if desired)
NEW!	6. UV Paint for Outdoor Operation	Less Fade/ Higher Performance
NEW!	7. Coupling Guard – Orange Peel	Non-Sparking Design – Ease of Maintenance
NEW!	8. Stainless Steel Baffle Rings	Increased Blower Efficiency
NEW!	9. Lip Seals	To Prevent Housing Contamination

\* The 1400 Series is not available on the Fast Delivery program

## Contact Your Gardner Denver Representative

For more information, contact your local representative or

### Gardner Denver Engineered Products Division

100 Gardner Park, Peachtree City, GA 30269

Toll Free 800-543-7736

Phone 770-632-5000 • Fax 770-486-5629

E-mail: [blowersmktg@gardnerdenver.com](mailto:blowersmktg@gardnerdenver.com)

Visit our website: [www.gardnerdenver.com](http://www.gardnerdenver.com)

**For Parts Information, Contact:**

Gardner Denver Engineered Products Division Customer Service

Toll Free 800-982-3009

770-632-5000 FAX: 770-486-5530

# Gardner Denver®